



MOBILE TOOL CABINET 1600MM WITH POWER TOOL CHARGING DRAWER

MODEL NO: **AP6310BE.V2**

Thank you for purchasing a Sealey product. Manufactured to a high standard, this product will, if used according to these instructions, and properly maintained, give you years of trouble free performance.



IMPORTANT: PLEASE READ THESE INSTRUCTIONS CAREFULLY. NOTE THE SAFE OPERATIONAL REQUIREMENTS, WARNINGS & CAUTIONS. USE THE PRODUCT CORRECTLY AND WITH CARE FOR THE PURPOSE FOR WHICH IT IS INTENDED. FAILURE TO DO SO MAY CAUSE DAMAGE AND/OR PERSONAL INJURY AND WILL INVALIDATE THE WARRANTY. KEEP THESE INSTRUCTIONS SAFE FOR FUTURE USE.

1. SAFETY

- ❑ **WARNING!** Ensure Health & Safety, local authority, and general workshop practice regulations are adhered to when using these units.
- ❑ **WARNING!** Use the Rollcab on level and solid ground, preferably concrete.
- ✓ Keep the work area clean, uncluttered and ensure there is adequate lighting.
- ✓ Keep the units clean and tidy in accordance with good workshop practice.
- ✓ Keep children and unauthorised persons away from the work area.
- ✗ **DO NOT** use these units for any purpose other than that for which they are designed.
- ✗ **DO NOT** use the units outdoors.
- ✗ **DO NOT** place the units in a damp or wet location or an area where there is condensation.
- ✗ **DO NOT** clean the units with any solvents which may damage the surfaces or the protective coating.
- ✗ **DO NOT** move the units with the drawers out. To avoid tipping, open one drawer at a time and close and secure all drawers whilst moving the rollcab.
- ✗ **DO NOT** step on the drawers.
- ✗ **DO NOT** overload the drawers, weight limit per drawer is 36kg.

2. INTRODUCTION

All heavy-duty steel construction and manufactured with steel inner walls for extra strength and durability. Heavy-duty 45mm ball-bearing drawer slides provide superior performance, suitable for heavier loads. Full height rear locking mechanism, locks smooth running soft close drawers in place. Rust and solvent resistant black crinkle effect finish. Fitted with six Ø125mm PP wheels with black chrome effect alloys, two fixed, two swivel and two swivel with brakes. Each drawer features stylish black anodized heavy-duty drawer pulls plus pre-cut non-slip liners. Power tool charging drawer fitted with 4 x 230V sockets and 2 x 5V 2.4A USB sockets. Mounting points to fit additional four gang power strip - Model No. EL34USBB (not included). Stainless steel 'flip-top' split equally into 2-sections providing a work surface and additional storage. Two cylinder locks allow drawers and power tool charging drawer to be locked separately.

3. SPECIFICATION

Model No:.....**AP6310BE.V2**
Overall Size (W x D x H): 1600 x 584 x 988mm

Top Compartment (x2):
Overall Size (W x D x H):720 x 465 x 70mm
Small Section (W x D x H):.....720 x 200 x 70mm
Large Section (W x D x H):720 x 280 x 70mm

Power Tool Charging Area:
Overall Size (W x D x H):485 x 335 x 390mm
Top Section (W x D x H):.....485 x 335 x 150mm
Bottom Section (W x D x H):485 x 335 375mm



4. CONTENTS

ITEM	DESCRIPTION	QTY
1	Bolt M6 x 16 mm	14
2	Handle fig.1	1
3	Storage hooks fig.2	4
4	Bolt M3 x 10 mm (not shown)	4
5	Bottle opener fig.4	1

5. ASSEMBLY

- 5.1. These units are heavy, obtain the help of at least one other person before attempting to unpack them.
- 5.2. Mount the side mounted handle onto the left hand end of cabinet and attach with 4 bolts (item 1) (fig.1).
- 5.3. Mount the storage hooks using bolts (item 1) at each end of the cabinet (fig.2) or alternatively mount one set of hooks on reverse face of either left or right hand end of cabinet (fig.2).
- 5.4. To remove a drawer with roller sliders, pull the drawer completely out, press down the right tab and lift up the left tab, pull drawer off the slides To reinstall the drawer, realign with the internal drawer slide and push until it locks in place (fig.3).
- 5.5. Fit bottle opener to the left hand (handle) end of the cabinet using two M6 x 16 mm bolts.(fig.4).

5.6. Mounting holes for an additional power rail (EL34USBB - not included) are provided at both ends of the cabinet and mounting bolts (item 4) are provided with the cabinet.

IMPORTANT: To avoid tipping, open one drawer at a time and close and secure all drawers whilst moving the rollcab/units.

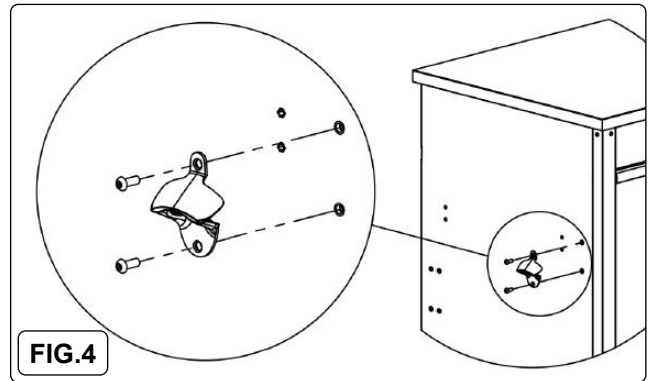
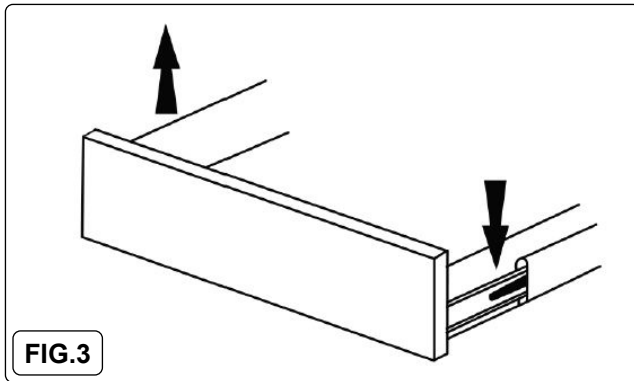
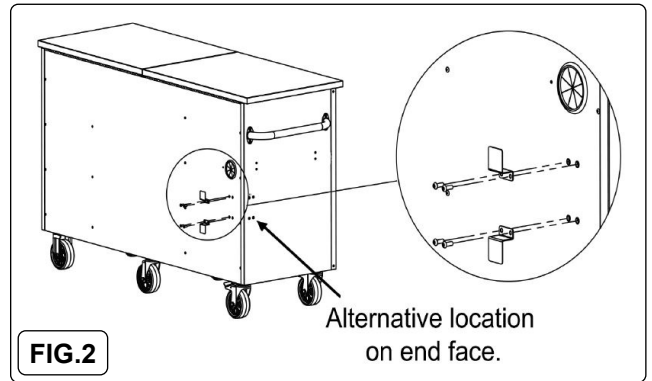
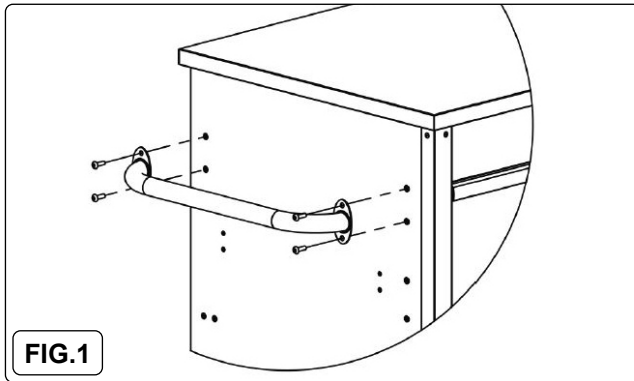

6. MAINTENANCE

- 6.1. Periodically lubricate wheel axles and tighten all nuts and bolts.
- 6.2. Keep all surfaces clean. Brush off and wipe down with damp cloth and mild detergent to maintain finish.
- 6.3. Lubricate the drawer slides sparingly every six months.
- 6.4. Stubborn grease and oil marks can be removed by using a non-abrasive cleaner.



ENVIRONMENT PROTECTION

Recycle unwanted materials instead of disposing of them as waste. All tools, accessories and packaging should be sorted, taken to a recycling centre and disposed of in a manner which is compatible with the environment. When the product becomes completely unserviceable and requires disposal, drain any fluids (if applicable) into approved containers and dispose of the product and fluids according to local regulations.



REGISTER YOUR PURCHASE HERE

Note: It is our policy to continually improve products and as such we reserve the right to alter data, specifications and component parts without prior notice. Please note that other versions of this product are available. If you require documentation for alternative versions, please email or call our technical team on technical@sealey.co.uk or 01284 757505.

Important: No Liability is accepted for incorrect use of this product.

Warranty: Guarantee is 5 years from purchase date, proof of which is required for any claim.

Sealey Group, Kempson Way, Suffolk Business Park, Bury St Edmunds, Suffolk. IP32 7AR



01284 757500



sales@sealey.co.uk



www.sealey.co.uk